



ITronic
powered by AMN

A Joint Venture between AMN International and IT Group Europe



Solutions



Exterior



Interior



Switches and
Top-Column modules



Optical systems



Sensors



AC-/DC-motors



Others



Products

Developing Inspection Technology for all automotive devices

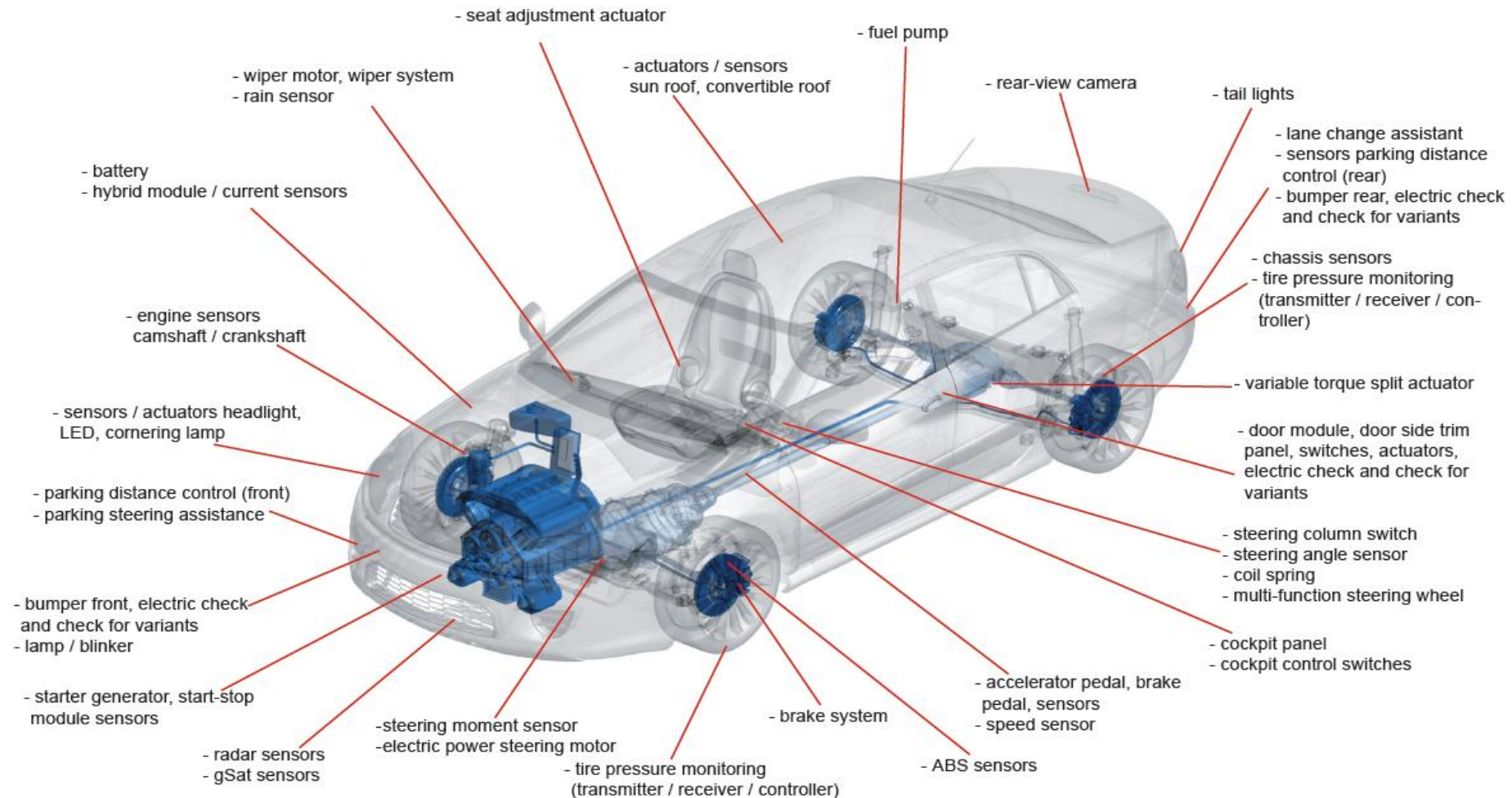

Assembly / Test Station for Automotive Bumpers



[VIDEO](#)

Automated functional and optical inspection for complex bumper assemblies.

This system enables **reliable in-line or end-of-line testing** of automotive bumpers with integrated sensors, lighting, and decorative components. Modular fixtures ensure precise positioning, while high-resolution cameras and electrical test units verify **completeness, position, and functionality** in a single process.

Value added:

- ▶ Parallel testing for higher throughput
- ▶ Optical inspection of large surfaces and assembled components
- ▶ Electrical testing of PDC, lighting, and sensor systems
- ▶ Modular design for fast variant changeover
- ▶ Full traceability and data analysis via TST-WIN
- ▶ Reduced scrap and rework through early defect detection

End-of-Line Test System for Door Modules

▶ Automated functional and optical testing for complete door modules.

This end-of-line system performs **fully automated testing of assembled door modules**, verifying electrical, functional, and optical characteristics in a single test sequence. The station ensures correct operation of switches, actuators, lighting elements, and wiring while guaranteeing variant compliance and data traceability.

Value added:

- ▶ End-of-line verification of fully assembled door modules
- ▶ Electrical and functional testing of integrated components
- ▶ Optical inspection for completeness and correct positioning
- ▶ Variant-dependent test sequences via TST-WIN
- ▶ Full traceability with statistics and data export
- ▶ Reduced rework and scrap before shipment

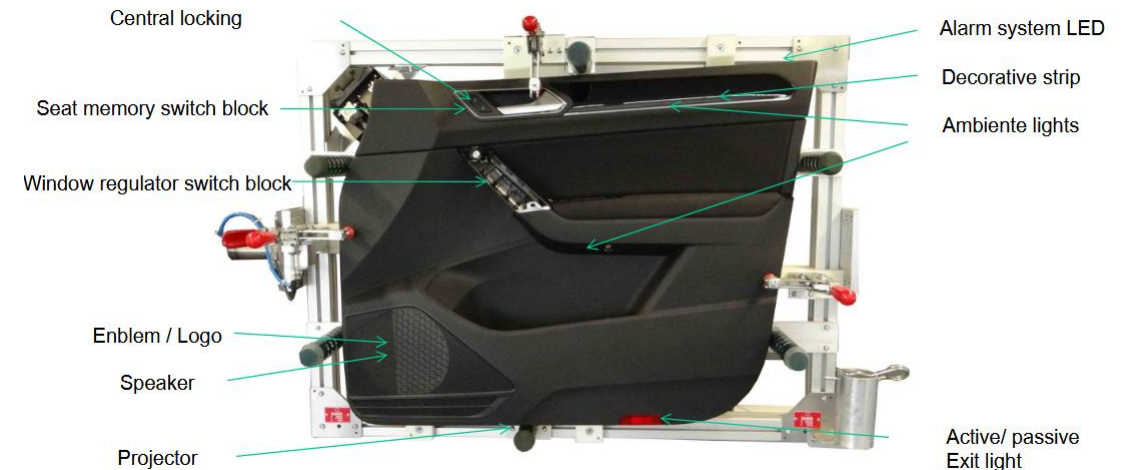

[VIDEO](#)

Switches and Top-Column Modules

Fully Automatic Top-Column Module Test System

This high-capacity test system validates **all lever and button functions** of steering column top modules using **multiple independent robotic test cells**. Each cell employs a 6-axis robot for precise actuation and **force/torque measurement**, ensuring repeatable and reliable results under production conditions.

Value added:

- ▶ Simultaneous testing of multiple modules for maximum throughput
- ▶ 6-axis robotic actuation with integrated force/torque measurement
- ▶ Mechanical, electromechanical, and electronic test coverage
- ▶ Variant-dependent testing and MES connectivity via TST-WIN
- ▶ Complete data logging and traceability
- ▶ Ideal for final assembly and end-of-line quality control

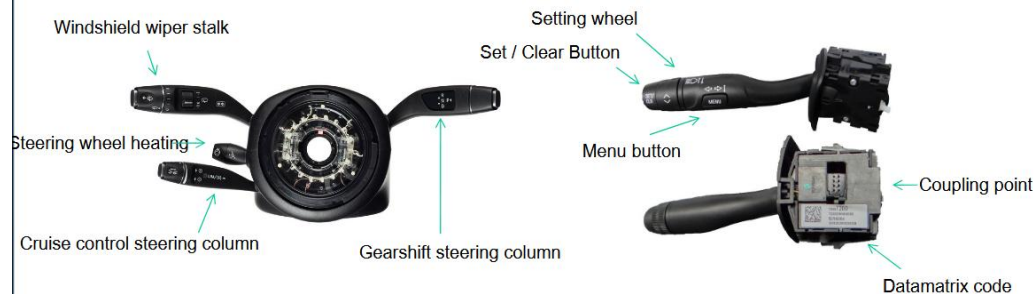

E- Check IT

Universal Electrical Measurement System

Compact and modular system for electrical and electronic testing in industrial and automotive environments.

It enables precise measurements of current, resistance, and component presence, with easy integration into production lines or laboratories.

Value added:

- ▶ Portable and flexible design (only 1 kg)
- ▶ High precision ($\pm 0.1\%$) and 16 measurement channels
- ▶ Compatible with OPC-UA, IoT, and remote maintenance
- ▶ Configurable for multiple variants and products
- ▶ Ideal for in-line and end-of-line testing



[E-Check IT - YouTube](#)

Itronic Contact Adaptors

- ▶ Personalized Fixtures
- ▶ Up to 1 Million cycles
- ▶ Pins 20K to 50K cycles
- ▶ Easily substituted

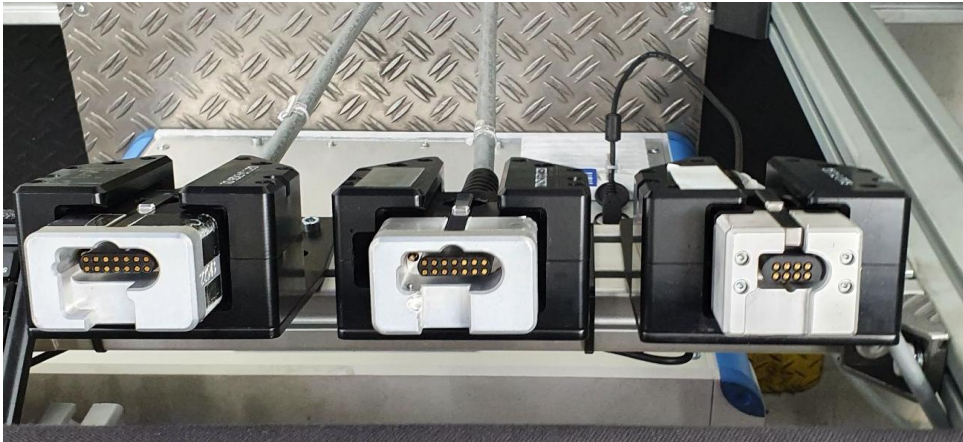

Blind Audit



[Video - Blind Audit](#)

Interactive Assembly Control with Instant Reporting

Combines operator visual verification with intelligent software to ensure the correct assembly of parts, variants, and colors in automotive production lines.

Ideal for **end-of-line stations** or critical inspection points where **traceability and repeatability** are essential.

Key benefits and attributes:

- ▶ Eliminates human errors through visual guidance and programmable inspection logic.
- ▶ Real-time verification of variants, colors, and components.
- ▶ Automatic recording of results and photographic evidence for complete traceability.
- ▶ Intuitive and multilingual interface, easy to use and train.
- ▶ Integration with MES/JIS systems and quality databases.
- ▶ Modular and scalable configuration, adaptable to different products or lines.
- ▶ Compliance with automotive standards and reduction of rework or rejects.

Terahertz

- ▶ Terahertz - Measuring multilayer paint thickness & radar
- ▶ Test scopes
 - ▶ Multilayer measurement & variety of materials
 - ▶ Measurement of radar characteristics
- ▶ Fields of application
 - ▶ Layer thickness measurement of paintwork on plastic and metal
 - ▶ Radar reflection and transmission measurement
 - ▶ Layer structure testing of molded parts such as dashboards
 - ▶ Fault detection in plastic parts
 - ▶ Testing coatings on ceramics
 - ▶ Thickness of coatings on fiber reinforced plastics
 - ▶ Conductivity and layer thickness of coatings on fuel cells/batteries



DOBOT & RoboInspecto

DOBOT & RoboInspector collaborative industrial robots

Scope

- ▶ Checking, testing and measuring
- ▶ Handling & Assembly
- ▶ Machining & Installation

Fields of application

- ▶ Automotive assemblies such as door panels, bumpers, steering column switch modules or electric seat adjusters.
- ▶ Household appliances
- ▶ Consumer electronics
- ▶ Power tools
- ▶ Medical devices



[Video](#)



ITronic
powered by AMN



ITronic
powered by AMN

Thank you!

Contact Information:

Email: info_mx@itgroup-europe.com

Cel: +1 915 224 4105

